

art

POWER CARRYING SOLUTIONS



TOPRAKLAMA ELEMANLARI

GROUNDING ELEMENTS



AT SERIES

TOPRAKLAMA ELEMANLARI

GROUNDING ELEMENTS

PREGALVANİZ (PG)
PREGALVANIZED (PG)
TS EN 10346

SICAK DALDIRMA (SD)
HOT DIP GALVANIZED (HDG)
TS EN ISO 1461

TOPRAKLAMA ŞERİDİ / GROUNDING STRAP

PG

Sipariş Kodu Order Code	W (mm)	T (mm)	Ağırlık (kg/m) Weight (kg/m)	Barkod Kodu Barcode Code
ATS 30-3	30	3.00 mm	0,707	2004400
ATS 30-4	30	4.00 mm	0,942	2004401
ATS 40-3	40	3.00 mm	0,942	2004402
ATS 40-4	40	4.00 mm	1,256	2004403

SD / HDG

Sipariş Kodu Order Code	W (mm)	T (mm)	Ağırlık (kg/m) Weight (kg/m)	Barkod Kodu Barcode Code
ATS 30-3	30	3.00 mm	0,778	2004400
ATS 30-4	30	4.00 mm	1,036	2004401
ATS 40-3	40	3.00 mm	1,036	2004402
ATS 40-4	40	4.00 mm	1,382	2004403

W = GENİŞLİK = WIDTH / T = KALINLIK = THICKNESS



GALVANİZLİ MONO TEL / GALVANISED MONO CONDUCTOR

SD/HDG

Sipariş Kodu Order Code	Ebat (mm) Size (mm)	KESİT (mm)	Ağırlık (kg/m) Weight (kg/m)	Barkod Kodu Barcode Code
AMT 08	M8	50	0,430	2004410
AMT 10	M10	70	0,642	2004411



ARTIM METAL ELEKTRİK A.Ş.

* Farklı kalınlık ve ölçülerde üretim yapılabılır.
* Malzeme ağırlıkları yaklaşık değerlerdir, \pm %10 değişiklik gösterebilir.
* Malzeme kalınlık toleransı \pm %10 dur.
* Lütfen siparişlerinizde sipariş kodu veya ürün kodu ve Kaplama şeklini belirtiniz.

* We can produce cable trays different thickness and dimensions
* Cable trays are shown approximately weight, they could change \pm %10 difference.
* Cable trays thickness tolerances are shown \pm %10 .
* Please indicate order code and coating type in your orders.

AT SERIES

TOPRAKLAMA ELEMANLARI

GROUNDING ELEMENTS

PREGALVANİZ (PG)
PREGALVANIZED (PG)
TS EN 10346

BAĞLANTI KLEMENSİ / JOINTING CLAMP

Sipariş Kodu Order Code	W1 (mm)	W2 (mm)	Ağırlık (kg/ad) Weight (kg/pcs)	Paket Miktarı (Ad) Package Content (Pcs)	PG
					Barkod Kodu Barcode Code
ATK 301	30	30	0,121	100	2004420
ATK 302	30	Q22	0,137	75	2004421
ATK 401	40	40	0,300	75	2004423
ATK 402	40	Q22	0,300	50	2004424

W = GENİŞLİK = WIDTH / T = KALINLIK = THICKNESS



1 Adet Klemens için;
4 adet M6x15 Anahtar Baslı Civata + 4 adet M6 Somun kullanılmaktadır.
Ürün Civata Somun dahil Takim olarak satılmaktadır.
For One piece Jointing Clamp;
4 Piece M6x15 Key Head Bolts + 4 Piece M6 Nuts are used.
The product is sold as a Set including Bolt Nut.

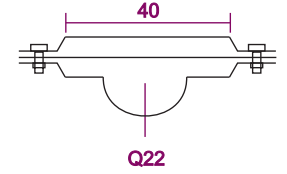
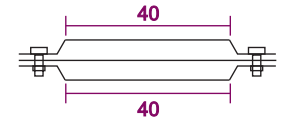
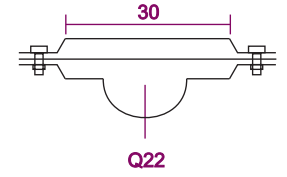
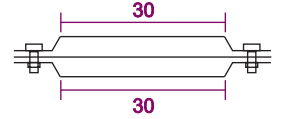

BAĞLANTI KLEMENSİ / JOINTING CLAMP

Sipariş Kodu Order Code	İletken Conductor	Kesit Section	Ağırlık (kg/ad) Weight (kg/pcs)	PG
				Barkod Kodu Barcode Code
ATKA 01	16-20	30x3	0,080	2004481
ATKA 02	22-26	30x3	0,090	2004482
ATKA 03	28-32	30x3	0,090	2004483
ATKA 04	16-20	30x3	0,120	2004484
ATKA 05	26-32	40x4	0,400	2004485



* Farklı kalınlık ve ölçülerde üretim yapılabılır.
* Malzeme ağırlıkları yaklaşık değerlerdir, ± %10 değişiklik gösterebilir.
* Malzeme kalınlık toleransı ± %10 dur.
* Lütfen siparişlerinizde sipariş kodu veya ürün kodu ve Kaplama şeklini belirtiniz.

* We can produce cable trays different thickness and dimensions
* Cable trays are shown approximately weight, they could change ± %10 difference.
* Cable trays thickness tolerances are shown ± %10 .
* Please indicate order code and coating type in your orders.

AT SERIES

TOPRAKLAMA ELEMANLARI

GROUNDING ELEMENTS

SICAK DALDIRMA (SD)

HOT DIP GALVANIZED (HDG)

TS EN ISO 1461



TOPRAKLAMA ELEKTRODU / EARTHING ELECTRODE

4.00 mm

Sipariş Kodu Order Code	Ebat (mm) Size (mm)	L (mm)	Ağırlık (kg/ad) Weight (kg/pcs)	Barkod Kodu Barcode Code
ATE 40x40x4 -10	40x40	1.000	2,512	2004430
ATE 40x40x4 -15	40x40	1.500	3,768	2004431
ATE 50x50x4 -10	50x50	1.000	3,140	2004432
ATE 50x50x4 -15	50x50	1.500	4,710	2004433
ATE 60x60x4 -10	60x60	1.000	3,768	2004434
ATE 60x60x4 -15	60x60	1.500	5,652	2004435

5.00 mm

Sipariş Kodu Order Code	Ebat (mm) Size (mm)	L (mm)	Ağırlık (kg/ad) Weight (kg/pcs)	Barkod Kodu Barcode Code
ATE 40x40x5 -10	40x40	1.000	3,140	2004436
ATE 40x40x5 -15	40x40	1.500	4,710	2004437
ATE 50x50x5 -10	50x50	1.000	3,925	2004438
ATE 50x50x5 -15	50x50	1.500	5,888	2004439
ATE 60x60x5 -10	60x60	1.000	4,710	2004440
ATE 60x60x5 -15	60x60	1.500	7,065	2004441
ATE 65x65x5 -10	65x65	1.000	5,102	2004442
ATE 65x65x5 -15	65x65	1.500	7,653	2004443

6.00 mm

Sipariş Kodu Order Code	Ebat (mm) Size (mm)	L (mm)	Ağırlık (kg/ad) Weight (kg/pcs)	Barkod Kodu Barcode Code
ATE 60x60x6 -10	60x60	1.000	5,652	2004444
ATE 60x60x6 -15	60x60	1.500	8,478	2004445
ATE 65x65x6 -10	65x65	1.000	6,123	2004446
ATE 65x65x6 -15	65x65	1.500	9,184	2004447

L = BOY = LENGTH



Elektro Galvaniz talep üzerine de üretilebilir.
Electro Galvanized can also be produced upon request.

TOPRAKLAMA ÇUBUĞU / EARTHING ROD

Sipariş Kodu Order Code	Ebat (mm) Size (mm)	L (mm)	Ağırlık (kg/ad) Weight (kg/pcs)	Barkod Kodu Barcode Code
ATEC Q16 -10	Q16	1.000	1,600	2004451
ATEC Q16 -15	Q16	1.500	2,400	2004452
ATEC Q18 -10	Q18	1.000	2,100	2004453
ATEC Q18 -15	Q18	1.500	3,100	2004454
ATEC Q20 -10	Q20	1.000	2,600	2004455
ATEC Q20 -15	Q20	1.500	3,900	2004456

L = BOY = LENGTH



Beyaz ve Sarı olarak üretilebilir.
It can be produced in white and yellow.

ARTIM METAL ELEKTRİK A.Ş.

* Farklı kalınlık ve ölçülerde üretim yapılabılır.
* Malzeme ağırlıkları yaklaşık değerlerdir, \pm %10 değişiklik gösterebilir.
* Malzeme kalınlık toleransı \pm %10 dur.
* Lütfen siparişlerinizde sipariş kodu veya ürün kodu ve Kaplama şeklini belirtiniz.

* We can produce cable trays different thickness and dimensions
* Cable trays are shown approximately weight, they could change \pm %10 difference.
* Cable trays thickness tolerances are shown \pm %10 .
* Please indicate order code and coating type in your orders.

AT SERIES

TOPRAKLAMA ELEMANLARI

GROUNDING ELEMENTS

PREGALVANİZ (PG)
PREGALVANIZED (PG)
TS EN 10346

PARATONERLER / ACTIVE LIGHTNING CONDUCTORS

Sipariş Kodu Order Code	Ebat (m) Size (m)	L (m)	Ağırlık (kg/ad) Weight (kg/pcs)	Barkod Kodu Barcode Code
AYP TS 01	0,85 m	60	9,360	2004461
AYP TFTC	75X37x111		0,130	2004462
AYP TK 01	-	5	0,300	2004463
AYP TK 02	-	10	0,600	2004464

MAXİMUM KORUMA ÇAPI / PROTECTED DIAMETRE = 214 MT

Uygunluk Test Belgesi / Test Certificated of conformity in



AYP TS 01



AYP TFTC



AYP TK

Maximum Koruma Çapı = 214 MT. ,Uygunluk Test Belgesi.
Protected Diametre = 214 MT. , Test Certificated of conformity in.

PARATONERLER / ACTIVE LIGHTNING CONDUCTORS

Sipariş Kodu Order Code	Ebat (m) Size (m)	L (m)	Ağırlık (kg/ad) Weight (kg/pcs)	Barkod Kodu Barcode Code
AYP FP 01	0,50 m	60	3,000	2004465
AYP TFTC	75X37x111	-	0,130	2004462
AYP TK 01	-	5	0,300	2004463
AYP TK 02	-	10	0,600	2004464

MAXİMUM KORUMA ÇAPI / PROTECTED DIAMETRE = 214 MT

Uygunluk Test Belgesi / Test Certificated of conformity in



AYP FP 01



AYP TFTC



AYP TK

Maximum Koruma Çapı = 214 MT. ,Uygunluk Test Belgesi.
Protected Diametre = 214 MT. , Test Certificated of conformity in.

* Farklı kalınlık ve ölçülerde üretim yapılabılır.
* Malzeme ağırlıkları yaklaşık değerlerdir, \pm %10 değişiklik gösterebilir.
* Malzeme kalınlık toleransı \pm %10 dur.
* Lütfen siparişlerinizde sipariş kodu veya ürün kodu ve Kaplama şeklini belirtiniz.

* We can produce cable trays different thickness and dimensions
* Cable trays are shown approximately weight, they could change \pm %10 difference.
* Cable trays thickness tolerances are shown \pm %10 .
* Please indicate order code and coating type in your orders.

AT SERIES

TOPRAKLAMA ELEMANLARI

GROUNDING ELEMENTS

PREGALVANİZ (PG)

PREGALVANIZED (PG)

TS EN 10346

ORTA TİP TABAN / MIDDLE TYPE BASE

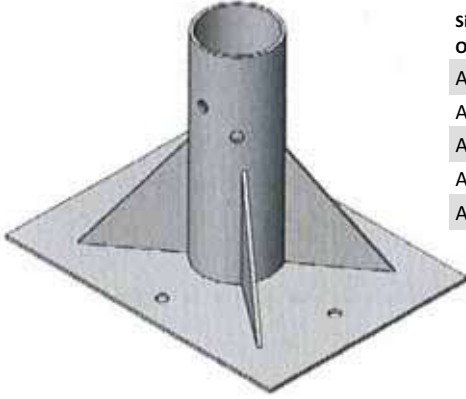

Sipariş Kodu Order Code	Direk Çapı Pole Diameter	Ağırlık (kg/ad) Weight (kg/pcs)	Barkod Kodu Barcode Code
AYS OTT 01	1.25 "	3,500	2004471
AYS OTT 02	1.50 "	4,000	2004472
AYS OTT 03	2.00 "	4,500	2004473
AYS OTT 04	2.50 "	5,000	2004474
AYS OTT 05	3.00 "	5,500	2004475

PG

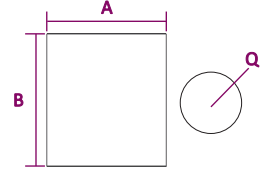

GERDİRME / TURNBUCKLE



Sipariş Kodu Order Code	Ebat (mm) Size (mm)	L (mm)	Ağırlık (kg/ad) Weight (kg/pcs)	Barkod Kodu Barcode Code
ATG 01	M6	100	0,085	2004451
ATG 02	M8	125	0,100	2004452
ATG 03	M10	150	0,125	2004453
ATG 04	M12	200	0,150	2004454
ATG 05	M16	250	0,200	2004455
ATG 06	M18	280	0,225	2004456

L = BOY = LENGTH



ARTIM METAL ELEKTRİK A.Ş.

- * Farklı kalınlık ve ölçülerde üretim yapılabılır.
- * Malzeme ağırlıkları yaklaşık değerlerdir, \pm %10 değişiklik gösterebilir.
- * Malzeme kalınlık toleransı \pm %10 dur.
- * Lütfen siparişlerinizde sipariş kodu veya ürün kodu ve Kaplama şeklini belirtiniz.

- * We can produce cable trays different thickness and dimensions
- * Cable trays are shown approximately weight, they could change \pm %10 difference.
- * Cable trays thickness tolerances are shown \pm %10 .
- * Please indicate order code and coating type in your orders.

AT SERIES

TOPRAKLAMA ELEMANLARI

GROUNDING ELEMENTS

PREGALVANİZ (PG)
PREGALVANIZED (PG)
TS EN 10346

L BAĞLANTI KLEMENSİ / L JOINTING CLAMP

PG

Sipariş Kodu Order Code	İletken Conductor	Ağırlık (kg/ad) Weight (kg/pcs)	Barkod Kodu Barcode Code
ATLK 01	2.00 mm	0,020	2004495
ATLK 02	2.00 mm	0,042	2004496

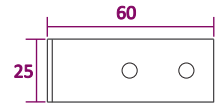
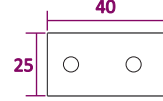
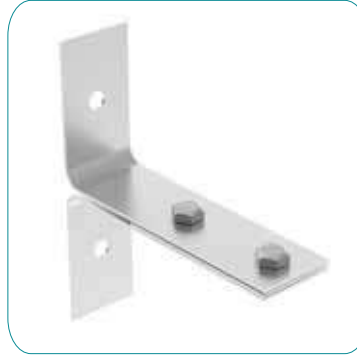

1 Adet Klemens için;
2 adet M6x15 Anahtar Baslı Civata + 2 adet M6 Somun kullanılmaktadır.
Ürün Civata Somun dahil Takim olarak satılmaktadır.
For One piece Jointing Clamp;
2 Piece M6x15 Key Head Bolts + 2 Piece M6 Nuts are used.
The product is sold as a Set including Bolt Nut.

L BAĞLANTI KLEMENSİ / L JOINTING CLAMP

PG

Sipariş Kodu Order Code	İletken Conductor	Ağırlık (kg/ad) Weight (kg/pcs)	Barkod Kodu Barcode Code
ATLK 03	2.00 mm	0,024	2004497
ATLK 02	2.00 mm	0,042	2004496

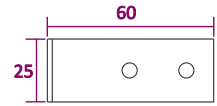
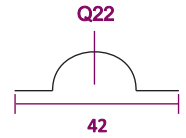

1 Adet Klemens için;
2 adet M6x15 Anahtar Baslı Civata + 2 adet M6 Somun kullanılmaktadır.
Ürün Civata Somun dahil Takim olarak satılmaktadır.
For One piece Jointing Clamp;
2 Piece M6x15 Key Head Bolts + 2 Piece M6 Nuts are used.
The product is sold as a Set including Bolt Nut.

* Farklı kalınlık ve ölçülerde üretim yapılabılır.
* Malzeme ağırlıkları yaklaşık değerlerdir, \pm %10 değişiklik gösterebilir.
* Malzeme kalınlık toleransı \pm %10 dur.
* Lütfen siparişlerinizde sipariş kodu veya ürün kodu ve Kaplama şeklini belirtiniz.

* We can produce cable trays different thickness and dimensions
* Cable trays are shown approximately weight, they could change \pm %10 difference.
* Cable trays thickness tolerances are shown \pm %10 .
* Please indicate order code and coating type in your orders.

AT SERIES

TOPRAKLAMA ELEMANLARI

GROUNDING ELEMENTS

CİVATA TİP TESPİT KROŞELERİ / BOLT TYPE FIXING CLAMPS



PG			
Sipariş Kodu Order Code	İletken Conductor	Ağırlık (kg/ad) Weight (kg/pcs)	Barkod Kodu Barcode Code
ACTK 01	8 mm	0,080	2004480
BAKIR / COPPER			
Sipariş Kodu Order Code	İletken Conductor	Ağırlık (kg/ad) Weight (kg/pcs)	Barkod Kodu Barcode Code
ACTK 02	8 mm	0,090	2004480
PİRİNÇ / BRASS			
Sipariş Kodu Order Code	İletken Conductor	Ağırlık (kg/ad) Weight (kg/pcs)	Barkod Kodu Barcode Code
ACTK 03	8 mm	0,085	2004480

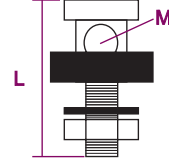

BRANŞMAN & DURDURUCU KLEMENSLER / JOINTING & STOPPING CLAMPS



AL			
Sipariş Kodu Order Code	Kesit (mm ²) Section (mm ²)	Ağırlık (kg/ad) Weight (kg/pcs)	Barkod Kodu Barcode Code
ABK ALCU 01	A25-B16	0,025	2004481
ABK ALCU 02	A40-B25	0,031	2004482
ABK ALCU 03	A70-B50	0,056	2004483
ABK ALCU 04	A120-B70	0,092	2004484
ABK ALCU 05	A240-B120	0,215	2004485
AL			
Sipariş Kodu Order Code	Kesit (mm ²) Section (mm ²)	Ağırlık (kg/ad) Weight (kg/pcs)	Barkod Kodu Barcode Code
ADK ALCU 01	16-50	0,070	2004491
ADK ALCU 02	50-95	0,122	2004492

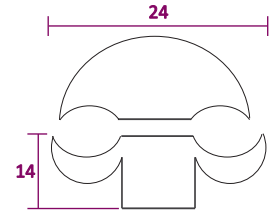

ARTIM METAL ELEKTRİK A.Ş.

* Farklı kalınlık ve ölçülerde üretim yapılabılır.
* Malzeme ağırlıkları yaklaşık değerlerdir, ± %10 değişiklik gösterebilir.
* Malzeme kalınlık toleransı ± %10 dur.
* Lütfen siparişlerinizde sipariş kodu veya ürün kodu ve kaplama şeklini belirtiniz.

* We can produce cable trays different thickness and dimensions
* Cable trays are shown approximately weight, they could change ± %10 difference.
* Cable trays thickness tolerances are shown ± %10 .
* Please indicate order code and coating type in your orders.

art

POWER CARRYING SOLUTIONS



GEMİ TİPİ KABLO KANALLARI

MARINE TYPE CABLE TRAYS



AG SERIES

H15 GEMI TIPI KABLO KANALLARI

H15 MARINE TYPE CABLE TRAYS

PREGALVANİZ (PG)
PREGALVANIZED (PG)
TS EN 10346



1.00 mm

Sipariş Kodu Order Code	W (mm)	T (mm)	Ağırlık (kg/m) Weight (kg/m)	Barkod Kodu Barcode Code
15 AGK 050-10	50	1.00 mm	0,523	2009001
15 AGK 100-10	100	1.00 mm	0,876	2009002
15 AGK 200-10	200	1.00 mm	1,583	2009003
15 AGK 300-10	300	1.00 mm	2,289	2009004

1.20 mm

Sipariş Kodu Order Code	W (mm)	T (mm)	Ağırlık (kg/m) Weight (kg/m)	Barkod Kodu Barcode Code
15 AGK 050-12	50	1.20 mm	0,627	2009005
15 AGK 100-12	100	1.20 mm	1,051	2009006
15 AGK 200-12	200	1.20 mm	1,899	2009007
15 AGK 300-12	300	1.20 mm	2,747	2009008

1.50 mm

Sipariş Kodu Order Code	W (mm)	T (mm)	Ağırlık (kg/m) Weight (kg/m)	Barkod Kodu Barcode Code
15 AGK 050-15	50	1.50 mm	0,784	2009009
15 AGK 100-15	100	1.50 mm	1,314	2009010
15 AGK 200-15	200	1.50 mm	2,374	2009011
15 AGK 300-15	300	1.50 mm	3,434	2009012

H = YÜKSEKLİK = HEIGHT / W = GENİŞLİK = WIDTH / T = KALINLIK = THICKNESS

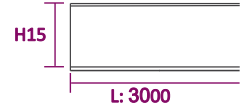

SICAK DALDIRMA (SD)
HOT DIP GALVANIZED (SD)
TS EN ISO 1461

1.00 mm

Sipariş Kodu Order Code	W (mm)	T (mm)	Ağırlık (kg/m) Weight (kg/m)	Barkod Kodu Barcode Code
15 AGK 050-10	50	1.00 mm	0,575	2009001
15 AGK 100-10	100	1.00 mm	0,964	2009002
15 AGK 200-10	200	1.00 mm	1,741	2009003
15 AGK 300-10	300	1.00 mm	2,518	2009004

1.20 mm

Sipariş Kodu Order Code	W (mm)	T (mm)	Ağırlık (kg/m) Weight (kg/m)	Barkod Kodu Barcode Code
15 AGK 050-12	50	1.20 mm	0,690	2009005
15 AGK 100-12	100	1.20 mm	1,156	2009006
15 AGK 200-12	200	1.20 mm	2,089	2009007
15 AGK 300-12	300	1.20 mm	3,022	2009008

1.50 mm

Sipariş Kodu Order Code	W (mm)	T (mm)	Ağırlık (kg/m) Weight (kg/m)	Barkod Kodu Barcode Code
15 AGK 050-15	50	1.50 mm	0,863	2009009
15 AGK 100-15	100	1.50 mm	1,445	2009010
15 AGK 200-15	200	1.50 mm	2,611	2009011
15 AGK 300-15	300	1.50 mm	3,777	2009012

H = YÜKSEKLİK = HEIGHT / W = GENİŞLİK = WIDTH / T = KALINLIK = THICKNESS

ARTIM METAL ELEKTRİK A.Ş.

* Farklı kalınlık ve ölçülerde üretim yapılabılır.
* Malzeme ağırlıkları yaklaşık değerlerdir, \pm %10 değişiklik gösterebilir.
* Malzeme kalınlık toleransı \pm %10 dur.
* Lütfen siparişlerinizde sipariş kodu veya ürün kodu ve Kaplama şeklini belirtiniz.

* We can produce cable trays different thickness and dimensions
* Cable trays are shown approximately weight, they could change \pm %10 difference.
* Cable trays thickness tolerances are shown \pm %10 .
* Please indicate order code and coating type in your orders.

AG SERIES

H15 GEMİ TIPI KABLO KANALLARI

H15 MARINE TYPE CABLE TRAYS

PREGALVANİZ (PG)
PREGALVANIZED (PG)
TS EN 10346

SICAK DALDIRMA (SD)
HOT DIP GALVANIZED (HDG)
TS EN ISO 1461

90° DÖNÜŞ ELEMANI / 90° BEND



				PG
Sipariş Kodu Order Code	W (mm)	T (mm)	Ağırlık (kg/ad) Weight (kg/ad)	Barkod Kodu Barcode Code
15 AGK 050Y	50	1.00 mm	0,384	2009031
15 AGK 100Y	100	1.00 mm	0,679	2009032
15 AGK 200Y	200	1.00 mm	1,296	2009033
15 AGK 300Y	300	1.00 mm	2,111	2009034

				SD/HDG
Sipariş Kodu Order Code	W (mm)	T (mm)	Ağırlık (kg/ad) Weight (kg/ad)	Barkod Kodu Barcode Code
15 AGK 050Y	50	1.00 mm	0,422	2009031
15 AGK 100Y	100	1.00 mm	0,747	2009032
15 AGK 200Y	200	1.00 mm	1,426	2009033
15 AGK 300Y	300	1.00 mm	2,322	2009034

H = YÜKSEKLİK = HEIGHT / W = GENİŞLİK = WIDTH / T = KALINLIK = THICKNESS

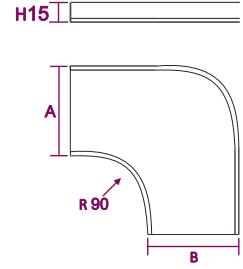

İÇ&DIŞ BÜKEY DÖNÜŞ (HAREKETLİ) / ADJUSTABLE INSIDE&OUTSIDE VERTICAL BENDS



				PG
Sipariş Kodu Order Code	W (mm)	T (mm)	Ağırlık (kg/ad) Weight (kg/ad)	Barkod Kodu Barcode Code
15 AGK 050B	50	1.00 mm	0,488	2009041
15 AGK 100B	100	1.00 mm	0,817	2009042
15 AGK 200B	200	1.00 mm	2,215	2009043
15 AGK 300B	300	1.00 mm	3,204	2009044

				SD/HDG
Sipariş Kodu Order Code	W (mm)	T (mm)	Ağırlık (kg/ad) Weight (kg/ad)	Barkod Kodu Barcode Code
15 AGK 050B	50	1.00 mm	0,537	2009041
15 AGK 100B	100	1.00 mm	0,899	2009042
15 AGK 200B	200	1.00 mm	2,437	2009043
15 AGK 300B	300	1.00 mm	3,524	2009044

H = YÜKSEKLİK = HEIGHT / W = GENİŞLİK = WIDTH / T = KALINLIK = THICKNESS

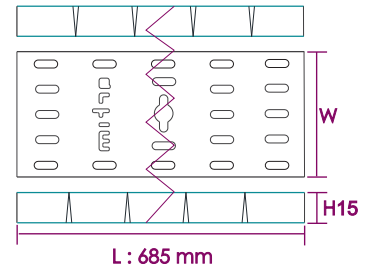

* Farklı kalınlık ve ölçülerde üretim yapılabılır.
* Malzeme ağırlıkları yaklaşık değerlerdir, ± %10 değişiklik gösterebilir.
* Malzeme kalınlık toleransı ± %10 dur.
* Lütfen siparişlerinizde sipariş kodu veya ürün kodu ve kaplama şeklini belirtiniz.

* We can produce cable trays different thickness and dimensions
* Cable trays are shown approximately weight, they could change ± %10 difference.
* Cable trays thickness tolerances are shown ± %10 .
* Please indicate order code and coating type in your orders.

AG SERIES

GEMİ TIPI KABLO MERDİVENİ

MARINE TYPE CABLE LADDER

SICAK DALDIRMA (SD)
HOT DIP GALVANIZED (SD)
TS EN ISO 1461



H40 Yan kenara 40x4 mm Silme lama demir kullanılır.
H50 Yan kenara 50x5 mm Silme lama demir kullanılır.
H40 Side edge 40x4 mm wipe blade iron is used.
H50 Side edge 50x5 mm wipe blade iron is used.

H40

Sipariş Kodu Order Code	W (mm)	T (mm)	Ağırlık (kg/m) Weight (kg/m)	Barkod Kodu Barcode Code
40 AGM 100-4	100	4.00 mm	2,813	2009051
40 AGM 150-4	150	4.00 mm	2,976	2009052
40 AGM 200-4	200	4.00 mm	3,140	2009053
40 AGM 250-4	250	4.00 mm	3,303	2009054
40 AGM 300-4	300	4.00 mm	3,466	2009055
40 AGM 400-4	400	4.00 mm	3,792	2009056
40 AGM 500-4	500	4.00 mm	4,119	2009057
40 AGM 600-4	600	4.00 mm	4,445	2009058

H = YÜKSEKLİK = HEIGHT / W = GENİŞLİK = WIDTH / T = KALINLIK = THICKNESS

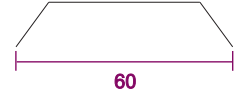

H50

Sipariş Kodu Order Code	W (mm)	T (mm)	Ağırlık (kg/m) Weight (kg/m)	Barkod Kodu Barcode Code
50 AGM 100-5	100	5.00 mm	4,212	2009059
50 AGM 150-5	150	5.00 mm	4,375	2009060
50 AGM 200-5	200	5.00 mm	4,539	2009061
50 AGM 250-5	250	5.00 mm	4,702	2009062
50 AGM 300-5	300	5.00 mm	4,865	2009063
50 AGM 400-5	400	5.00 mm	5,191	2009064
50 AGM 500-5	500	5.00 mm	5,518	2009065
50 AGM 600-5	600	5.00 mm	5,844	2009066

H = YÜKSEKLİK = HEIGHT / W = GENİŞLİK = WIDTH / T = KALINLIK = THICKNESS



H40

Sipariş Kodu Order Code	W (mm)	T (mm)	Ağırlık (kg/m) Weight (kg/m)	Barkod Kodu Barcode Code
40 AGM 100-4D	100	4.00 mm	2,720	2009071
40 AGM 150-4D	150	4.00 mm	2,877	2009072
40 AGM 200-4D	200	4.00 mm	3,035	2009073
40 AGM 250-4D	250	4.00 mm	3,193	2009074
40 AGM 300-4D	300	4.00 mm	3,351	2009075
40 AGM 400-4D	400	4.00 mm	3,666	2009076
40 AGM 500-4D	500	4.00 mm	3,982	2009077
40 AGM 600-4D	600	4.00 mm	4,297	2009078

H = YÜKSEKLİK = HEIGHT / W = GENİŞLİK = WIDTH / T = KALINLIK = THICKNESS

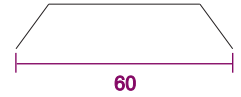
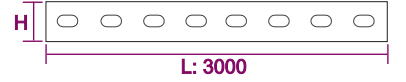

H50

Sipariş Kodu Order Code	W (mm)	T (mm)	Ağırlık (kg/m) Weight (kg/m)	Barkod Kodu Barcode Code
50 AGM 100-5D	100	5.00 mm	4,072	2009079
50 AGM 150-5D	150	5.00 mm	4,230	2009080
50 AGM 200-5D	200	5.00 mm	4,387	2009081
50 AGM 250-5D	250	5.00 mm	4,545	2009082
50 AGM 300-5D	300	5.00 mm	4,703	2009083
50 AGM 400-5D	400	5.00 mm	5,018	2009084
50 AGM 500-5D	500	5.00 mm	5,334	2009085
50 AGM 600-5D	600	5.00 mm	5,649	2009086

H = YÜKSEKLİK = HEIGHT / W = GENİŞLİK = WIDTH / T = KALINLIK = THICKNESS



TS 149 Elektro Galvaniz üretim de yapılmaktadır.
TS 149 Electro Galvanized production is also available.

ARTIM METAL ELEKTRİK A.Ş.

* Farklı kalınlık ve ölçülerde üretim yapılabılır.
* Malzeme ağırlıkları yaklaşık değerlerdir, \pm %10 değişiklik gösterebilir.
* Malzeme kalınlık toleransı \pm %10 dur.
* Lütfen siparişlerinizde sipariş kodu veya ürün kodu ve Kaplama şeklini belirtiniz.

* We can produce cable trays different thickness and dimensions
* Cable trays are shown approximately weight, they could change \pm %10 difference.
* Cable trays thickness tolerances are shown \pm %10 .
* Please indicate order code and coating type in your orders.

AG SERIES

GEMİ TIPI KABLO MERDİVENİ

MARINE TYPE CABLE LADDER

SICAK DALDIRMA (SD)

HOT DIP GALVANIZED (SD)

TS EN ISO 1461



H40 Yan kenara 40x4 mm Silme lama demir kullanılır.
H50 Yan kenara 50x5 mm Silme lama demir kullanılır.
H40 Side edge 40x4 mm wipe blade iron is used.
H50 Side edge 50x5 mm wipe blade iron is used.

H40

Sipariş Kodu Order Code	W (mm)	T (mm)	Ağırlık (kg/m) Weight (kg/m)	Barkod Kodu Barcode Code
40 AGMZ 100-4	100	4.00 mm	3,046	2009091
40 AGMZ 150-4	150	4.00 mm	3,326	2009092
40 AGMZ 200-4	200	4.00 mm	3,606	2009093
40 AGMZ 250-4	250	4.00 mm	3,886	2009094
40 AGMZ 300-4	300	4.00 mm	4,166	2009095
40 AGMZ 400-4	400	4.00 mm	4,725	2009096
40 AGMZ 500-4	500	4.00 mm	5,285	2009097
40 AGMZ 600-4	600	4.00 mm	5,844	2009098

H = YÜKSEKLİK = HEIGHT / W = GENİŞLİK = WIDTH / T = KALINLIK = THICKNESS

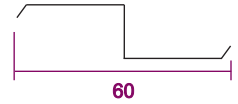

H50

Sipariş Kodu Order Code	W (mm)	T (mm)	Ağırlık (kg/m) Weight (kg/m)	Barkod Kodu Barcode Code
50 AGMZ 100-5	100	5.00 mm	4,445	2009099
50 AGMZ 150-5	150	5.00 mm	4,725	2009100
50 AGMZ 200-5	200	5.00 mm	5,005	2009101
50 AGMZ 250-5	250	5.00 mm	5,285	2009102
50 AGMZ 300-5	300	5.00 mm	5,564	2009103
50 AGMZ 400-5	400	5.00 mm	6,124	2009104
50 AGMZ 500-5	500	5.00 mm	6,683	2009105
50 AGMZ 600-5	600	5.00 mm	7,243	2009106

H = YÜKSEKLİK = HEIGHT / W = GENİŞLİK = WIDTH / T = KALINLIK = THICKNESS



H40

Sipariş Kodu Order Code	W (mm)	T (mm)	Ağırlık (kg/m) Weight (kg/m)	Barkod Kodu Barcode Code
40 AGMZ 100-4D	100	4.00 mm	2,945	2009071
40 AGMZ 150-4D	150	4.00 mm	3,215	2009072
40 AGMZ 200-4D	200	4.00 mm	3,486	2009073
40 AGMZ 250-4D	250	4.00 mm	3,756	2009074
40 AGMZ 300-4D	300	4.00 mm	4,027	2009075
40 AGMZ 400-4D	400	4.00 mm	4,568	2009076
40 AGMZ 500-4D	500	4.00 mm	5,108	2009077
40 AGMZ 600-4D	600	4.00 mm	5,649	2009078

H = YÜKSEKLİK = HEIGHT / W = GENİŞLİK = WIDTH / T = KALINLIK = THICKNESS

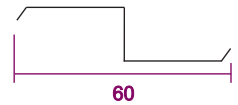
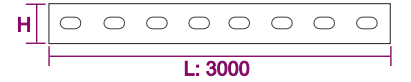

H50

Sipariş Kodu Order Code	W (mm)	T (mm)	Ağırlık (kg/m) Weight (kg/m)	Barkod Kodu Barcode Code
50 AGMZ 100-5D	100	5.00 mm	4,297	2009079
50 AGMZ 150-5D	150	5.00 mm	4,568	2009080
50 AGMZ 200-5D	200	5.00 mm	4,838	2009081
50 AGMZ 250-5D	250	5.00 mm	5,108	2009082
50 AGMZ 300-5D	300	5.00 mm	5,379	2009083
50 AGMZ 400-5D	400	5.00 mm	5,920	2009084
50 AGMZ 500-5D	500	5.00 mm	6,461	2009085
50 AGMZ 600-5D	600	5.00 mm	7,002	2009086

H = YÜKSEKLİK = HEIGHT / W = GENİŞLİK = WIDTH / T = KALINLIK = THICKNESS



H40 Yan kenara 40x4 mm Silme lama demir kullanılır.
H50 Yan kenara 50x5 mm Silme lama demir kullanılır.
H40 Side edge 40x4 mm wipe blade iron is used.
H50 Side edge 50x5 mm wipe blade iron is used.

TS 149 Elektro Galvaniz üretim de yapılmaktadır.
TS 149 Electro Galvanized production is also available.

- * Farklı kalınlık ve ölçülerde üretim yapılabılır.
- * Malzeme ağırlıkları yaklaşık değerlerdir, ± %10 değişiklik gösterebilir.
- * Malzeme kalınlık toleransı ± %10 dur.
- * Lütfen siparişlerinizde sipariş kodu veya ürün kodu ve Kaplama şeklini belirtiniz.

- * We can produce cable trays different thickness and dimensions
- * Cable trays are shown approximately weight, they could change ± %10 difference.
- * Cable trays thickness tolerances are shown ± %10 .
- * Please indicate order code and coating type in your orders.

AG SERIES

GEMİ TIPI KABLO MERDİVENİ 90° DÖNÜS

MARINE TYPE CABLE LADDER 90° BEND

SICAK DALDIRMA (SD)
HOT DIP GALVANIZED (SD)
TS EN ISO 1461



H40 Yan kenara 40x4 mm Silme lama demir kullanılır.
H50 Yan kenara 50x5 mm Silme lama demir kullanılır.
H40 Side edge 40x4 mm wipe blade iron is used.
H50 Side edge 50x5 mm wipe blade iron is used.

H40

Sipariş Kodu Order Code	W (mm)	T (mm)	Ağırlık (kg/ad) Weight (kg/ad)	Barkod Kodu Barcode Code
40 AGM 100Y	100	4.00 mm	1,085	2009121
40 AGM 150Y	150	4.00 mm	1,440	2009122
40 AGM 200Y	200	4.00 mm	1,796	2009123
40 AGM 250Y	250	4.00 mm	2,151	2009124
40 AGM 300Y	300	4.00 mm	2,506	2009125
40 AGM 400Y	400	4.00 mm	2,996	2009126
40 AGM 500Y	500	4.00 mm	3,484	2009127
40 AGM 600Y	600	4.00 mm	3,973	2009128

H = YÜKSEKLİK = HEIGHT / W = GENİŞLİK = WIDTH / T = KALINLIK = THICKNESS

H50

Sipariş Kodu Order Code	W (mm)	T (mm)	Ağırlık (kg/ad) Weight (kg/ad)	Barkod Kodu Barcode Code
50 AGM 100Y	100	5.00 mm	1,296	2009129
50 AGM 150Y	150	5.00 mm	1,707	2009130
50 AGM 200Y	200	5.00 mm	2,118	2009131
50 AGM 250Y	250	5.00 mm	2,529	2009132
50 AGM 300Y	300	5.00 mm	2,940	2009133
50 AGM 400Y	400	5.00 mm	3,483	2009134
50 AGM 500Y	500	5.00 mm	4,028	2009135
50 AGM 600Y	600	5.00 mm	4,572	2009136

H = YÜKSEKLİK = HEIGHT / W = GENİŞLİK = WIDTH / T = KALINLIK = THICKNESS

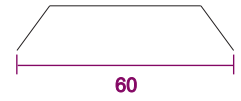
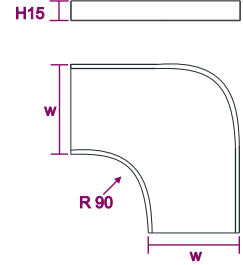

H40

Sipariş Kodu Order Code	W (mm)	T (mm)	Ağırlık (kg/ad) Weight (kg/ad)	Barkod Kodu Barcode Code
40 AGM 100YD	100	4.00 mm	1,031	2009137
40 AGM 150YD	150	4.00 mm	1,368	2009138
40 AGM 200YD	200	4.00 mm	1,706	2009139
40 AGM 250YD	250	4.00 mm	2,043	2009140
40 AGM 300YD	300	4.00 mm	2,381	2009141
40 AGM 400YD	400	4.00 mm	2,846	2009142
40 AGM 500YD	500	4.00 mm	3,310	2009143
40 AGM 600YD	600	4.00 mm	3,774	2009144

H = YÜKSEKLİK = HEIGHT / W = GENİŞLİK = WIDTH / T = KALINLIK = THICKNESS

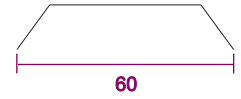
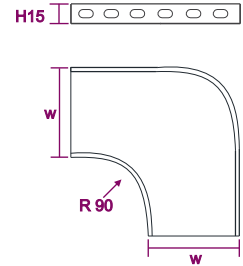

H50

Sipariş Kodu Order Code	W (mm)	T (mm)	Ağırlık (kg/ad) Weight (kg/ad)	Barkod Kodu Barcode Code
50 AGM 100YD	100	5.00 mm	1,231	2009145
50 AGM 150YD	150	5.00 mm	1,622	2009146
50 AGM 200YD	200	5.00 mm	2,012	2009147
50 AGM 250YD	250	5.00 mm	2,403	2009148
50 AGM 300YD	300	5.00 mm	2,793	2009149
50 AGM 400YD	400	5.00 mm	3,309	2009150
50 AGM 500YD	500	5.00 mm	3,827	2009151
50 AGM 600YD	600	5.00 mm	4,343	2009152

H = YÜKSEKLİK = HEIGHT / W = GENİŞLİK = WIDTH / T = KALINLIK = THICKNESS

ARTIM METAL ELEKTRİK A.Ş.

* Farklı kalınlık ve ölçülerde üretim yapılabılır.
* Malzeme ağırlıkları yaklaşık değerlerdir, ± %10 değişiklik gösterebilir.
* Malzeme kalınlık toleransı ± %10 dur.
* Lütfen siparişlerinizde sipariş kodu veya ürün kodu ve Kaplama şeklini belirtiniz.

* We can produce cable trays different thickness and dimensions
* Cable trays are shown approximately weight, they could change ± %10 difference.
* Cable trays thickness tolerances are shown ± %10 .
* Please indicate order code and coating type in your orders.

AG SERIES

GEMİ TIPI KABLO MERDİVENİ 90° DÖNÜS

MARINE TYPE CABLE LADDER 90° BEND

SICAK DALDIRMA (SD)

HOT DIP GALVANIZED (SD)

TS EN ISO 1461



H40 Yan kenara 40x4 mm Silme lama demir kullanılır.
H50 Yan kenara 50x5 mm Silme lama demir kullanılır.
H40 Side edge 40x4 mm wipe blade iron is used.
H50 Side edge 50x5 mm wipe blade iron is used.

H40

Sipariş Kodu Order Code	W (mm)	T (mm)	Ağırlık (kg/ad) Weight (kg/ad)	Barkod Kodu Barcode Code
40 AGMZ 100Y	100	4.00 mm	1,257	2009153
40 AGMZ 150Y	150	4.00 mm	1,708	2009154
40 AGMZ 200Y	200	4.00 mm	2,158	2009155
40 AGMZ 250Y	250	4.00 mm	2,609	2009156
40 AGMZ 300Y	300	4.00 mm	3,060	2009157
40 AGMZ 400Y	400	4.00 mm	3,739	2009158
40 AGMZ 500Y	500	4.00 mm	4,419	2009159
40 AGMZ 600Y	600	4.00 mm	5,099	2009160

H = YÜKSEKLİK = HEIGHT / W = GENİŞLİK = WIDTH / T = KALINLIK = THICKNESS

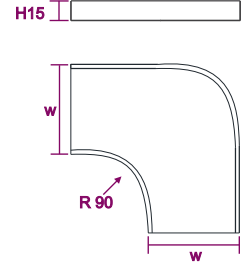

H50

Sipariş Kodu Order Code	W (mm)	T (mm)	Ağırlık (kg/ad) Weight (kg/ad)	Barkod Kodu Barcode Code
50 AGMZ 100Y	100	5.00 mm	1,467	2009161
50 AGMZ 150Y	150	5.00 mm	1,974	2009162
50 AGMZ 200Y	200	5.00 mm	2,480	2009163
50 AGMZ 250Y	250	5.00 mm	2,987	2009164
50 AGMZ 300Y	300	5.00 mm	3,492	2009165
50 AGMZ 400Y	400	5.00 mm	4,228	2009166
50 AGMZ 500Y	500	5.00 mm	4,963	2009167
50 AGMZ 600Y	600	5.00 mm	5,698	2009168

H = YÜKSEKLİK = HEIGHT / W = GENİŞLİK = WIDTH / T = KALINLIK = THICKNESS

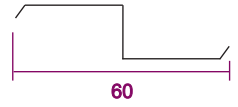

H40

Sipariş Kodu Order Code	W (mm)	T (mm)	Ağırlık (kg/ad) Weight (kg/ad)	Barkod Kodu Barcode Code
40 AGMZ 100YD	100	4.00 mm	1,194	2009169
40 AGMZ 150YD	150	4.00 mm	1,623	2009170
40 AGMZ 200YD	200	4.00 mm	2,050	2009171
40 AGMZ 250YD	250	4.00 mm	2,479	2009172
40 AGMZ 300YD	300	4.00 mm	2,907	2009173
40 AGMZ 400YD	400	4.00 mm	3,552	2009174
40 AGMZ 500YD	500	4.00 mm	4,198	2009175
40 AGMZ 600YD	600	4.00 mm	4,844	2009176

H = YÜKSEKLİK = HEIGHT / W = GENİŞLİK = WIDTH / T = KALINLIK = THICKNESS

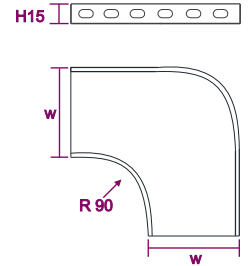

H40 Yan kenara 40x4 mm Silme lama demir kullanılır.
H50 Yan kenara 50x5 mm Silme lama demir kullanılır.
H40 Side edge 40x4 mm wipe blade iron is used.
H50 Side edge 50x5 mm wipe blade iron is used.

H50

Sipariş Kodu Order Code	W (mm)	T (mm)	Ağırlık (kg/ad) Weight (kg/ad)	Barkod Kodu Barcode Code
50 AGMZ 100YD	100	5.00 mm	1,394	2009177
50 AGMZ 150YD	150	5.00 mm	1,875	2009178
50 AGMZ 200YD	200	5.00 mm	2,356	2009179
50 AGMZ 250YD	250	5.00 mm	2,838	2009180
50 AGMZ 300YD	300	5.00 mm	3,317	2009181
50 AGMZ 400YD	400	5.00 mm	4,017	2009182
50 AGMZ 500YD	500	5.00 mm	4,715	2009183
50 AGMZ 600YD	600	5.00 mm	5,413	2009184

H = YÜKSEKLİK = HEIGHT / W = GENİŞLİK = WIDTH / T = KALINLIK = THICKNESS

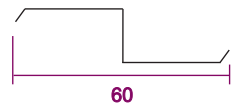

* Farklı kalınlık ve ölçülerde üretim yapılabılır.
* Malzeme ağırlıkları yaklaşık değerlerdir, ± %10 değişiklik gösterebilir.
* Malzeme kalınlık toleransı ± %10 dur.
* Lütfen siparişlerinizde sipariş kodu veya ürün kodu ve Kaplama şeklini belirtiniz.

* We can produce cable trays different thickness and dimensions
* Cable trays are shown approximately weight, they could change ± %10 difference.
* Cable trays thickness tolerances are shown ± %10 .
* Please indicate order code and coating type in your orders.

AG SERIES

GEMİ TIPI ASKI SİSTEMLERİ

MARINE TYPE SUPPORT SYSTEM

SICAK DALDIRMA (SD)
HOT DIP GALVANIZED (SD)
TS EN ISO 1461

KABLO MERDİVENİ EK PARÇASI / CABLE LADDERS STRAIGHT CONNECTORS

Sipariş Kodu Order Code	H (mm)	T (mm)	Ağırlık (kg/ad) Weight (kg/ad)	Barkod Kodu Barcode Code
40 AGM 01	40	4.00 mm	0,651	2009190
50 AGM 01	50	4.00 mm	0,763	2009191

H = YÜKSEKLİK = HEIGHT / T = KALINLIK = THICKNESS

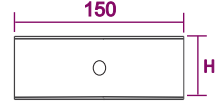

L ASKI AYAĞI / L HANGING SUPPORT

Sipariş Kodu Order Code	W (mm)	T (mm)	Ağırlık (kg/ad) Weight (kg/ad)	Barkod Kodu Barcode Code
AGLA 100	100	4.00 mm	0,145	2009201
AGLA 150	150	4.00 mm	0,197	2009202
AGLA 200	200	4.00 mm	0,249	2009203
AGLA 250	250	4.00 mm	0,300	2009204
AGLA 300	300	4.00 mm	0,352	2009205
AGLA 400	400	4.00 mm	0,456	2009206
AGLA 500	500	4.00 mm	0,560	2009207
AGLA 600	600	4.00 mm	0,663	2009208

W = GENİŞLİK = WIDTH / T = KALINLIK = THICKNESS

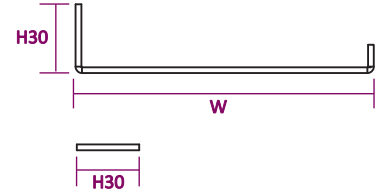

DELİKLİ L ASKI AYAĞI / PERFORATED L HANGING SUPPORT

Sipariş Kodu Order Code	W (mm)	T (mm)	Ağırlık (kg/ad) Weight (kg/ad)	Barkod Kodu Barcode Code
AGLAD 100	100	4.00 mm	0,133	2009209
AGLAD 150	150	4.00 mm	0,181	2009210
AGLAD 200	200	4.00 mm	0,229	2009211
AGLAD 250	250	4.00 mm	0,276	2009212
AGLAD 300	300	4.00 mm	0,324	2009213
AGLAD 400	400	4.00 mm	0,419	2009214
AGLAD 500	500	4.00 mm	0,515	2009215
AGLAD 600	600	4.00 mm	0,610	2009216

W = GENİŞLİK = WIDTH / T = KALINLIK = THICKNESS

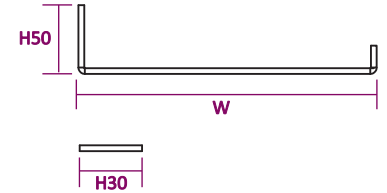

ARTIM METAL ELEKTRİK A.Ş.

* Farklı kalınlık ve ölçülerde üretim yapılabılır.
* Malzeme ağırlıkları yaklaşık değerlerdir, \pm %10 değişiklik gösterebilir.
* Malzeme kalınlık toleransı \pm %10 dur.
* Lütfen siparişlerinizde sipariş kodu veya ürün kodu ve Kaplama şeklini belirtiniz.

* We can produce cable trays different thickness and dimensions
* Cable trays are shown approximately weight, they could change \pm %10 difference.
* Cable trays thickness tolerances are shown \pm %10 .
* Please indicate order code and coating type in your orders.

AG SERIES

GEMİ TIPI ASKI SİSTEMLERİ

MARINE TYPE SUPPORT SYSTEM

SICAK DALDIRMA (SD)

HOT DIP GALVANIZED (SD)

TS EN ISO 1461



U KONSOL / U BRACKET

Sipariş Kodu Order Code	W (mm)	T (mm)	Ağırlık (kg/ad) Weight (kg/ad)	Barkod Kodu Barcode Code
AG UK 100	100	4.00 mm	0,176	2009251
AG UK 150	150	4.00 mm	0,228	2009252
AG UK 200	200	4.00 mm	0,280	2009253
AG UK 250	250	4.00 mm	0,332	2009254
AG UK 300	300	4.00 mm	0,383	2009255
AG UK 400	400	4.00 mm	0,487	2009256
AG UK 500	500	4.00 mm	0,591	2009257
AG UK 600	600	4.00 mm	0,694	2009258

W = GENİŞLİK = WIDTH / T = KALINLIK = THICKNESS

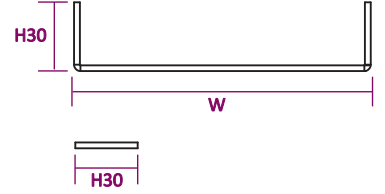

DELİKLİ U KONSOL / PERFORATED U BRACKET

Sipariş Kodu Order Code	W (mm)	T (mm)	Ağırlık (kg/ad) Weight (kg/ad)	Barkod Kodu Barcode Code
AG UKD 100	100	4.00 mm	0,162	2009259
AG UKD 150	150	4.00 mm	0,210	2009260
AG UKD 200	200	4.00 mm	0,257	2009261
AG UKD 250	250	4.00 mm	0,305	2009262
AG UKD 300	300	4.00 mm	0,353	2009263
AG UKD 400	400	4.00 mm	0,448	2009264
AG UKD 500	500	4.00 mm	0,543	2009265
AG UKD 600	600	4.00 mm	0,639	2009266

W = GENİŞLİK = WIDTH / T = KALINLIK = THICKNESS

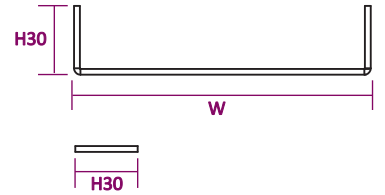

DELİKLİ UZUN U KONSOL / PERFORATED U LONG BRACKET

Sipariş Kodu Order Code	W (mm)	T (mm)	Ağırlık (kg/ad) Weight (kg/ad)	Barkod Kodu Barcode Code
AG UUKD 100	100	4.00 mm	0,238	2009267
AG UUKD 150	150	4.00 mm	0,290	2009268
AG UUKD 200	200	4.00 mm	0,342	2009269
AG UUKD 250	250	4.00 mm	0,394	2009270
AG UUKD 300	300	4.00 mm	0,446	2009271
AG UUKD 400	400	4.00 mm	0,549	2009272
AG UUKD 500	500	4.00 mm	0,653	2009273
AG UUKD 600	600	4.00 mm	0,756	2009274

W = GENİŞLİK = WIDTH / T = KALINLIK = THICKNESS

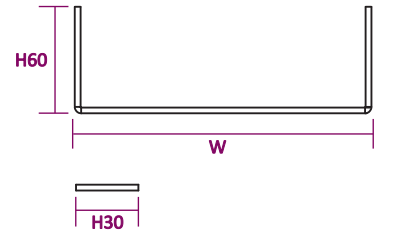

* Farklı kalınlık ve ölçülerde üretim yapılabilmektedir.
* Malzeme ağırlıkları yaklaşık değerlerdir, \pm %10 değişiklik gösterebilir.
* Malzeme kalınlık toleransı \pm %10 dur.
* Lütfen siparişlerinizde sipariş kodu veya ürün kodu ve kaplama şeklini belirtiniz.

* We can produce cable trays different thickness and dimensions
* Cable trays are shown approximately weight, they could change \pm %10 difference.
* Cable trays thickness tolerances are shown \pm %10 .
* Please indicate order code and coating type in your orders.

AG SERIES

GEMİ TIPI ASKI SİSTEMLERİ

MARINE TYPE SUPPORT SYSTEM

SICAK DALDIRMA (SD)
HOT DIP GALVANIZED (SD)
TS EN ISO 1461

F KONSOL / F BRACKET

Sipariş Kodu Order Code	W (mm)	T (mm)	Ağırlık (kg/ad) Weight (kg/ad)	Barkod Kodu Barcode Code
AG FK 100	100	4.00 mm	0,661	2009301
AG FK 150	150	4.00 mm	0,816	2009302
AG FK 200	200	4.00 mm	0,971	2009303
AG FK 250	250	4.00 mm	1,127	2009304
AG FK 300	300	4.00 mm	1,282	2009305
AG FK 400	400	4.00 mm	1,593	2009306
AG FK 500	500	4.00 mm	1,904	2009307
AG FK 600	600	4.00 mm	2,215	2009308

W = GENİŞLİK = WIDTH / T = KALINLIK = THICKNESS

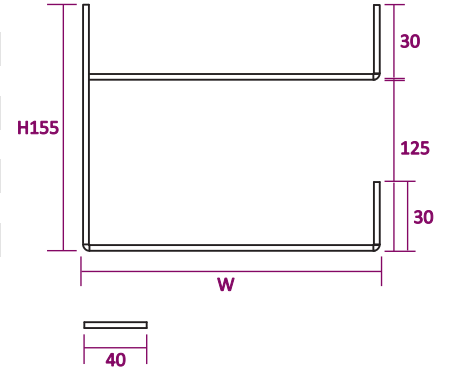

UZUN F KONSOL / F LONG BRACKET

Sipariş Kodu Order Code	W (mm)	T (mm)	Ağırlık (kg/ad) Weight (kg/ad)	Barkod Kodu Barcode Code
AG UFK 100	100	4.00 mm	0,878	2009309
AG UFK 150	150	4.00 mm	1,034	2009310
AG UFK 200	200	4.00 mm	1,189	2009311
AG UFK 250	250	4.00 mm	1,344	2009312
AG UFK 300	300	4.00 mm	1,500	2009313
AG UFK 400	400	4.00 mm	1,811	2009314
AG UFK 500	500	4.00 mm	2,122	2009315
AG UFK 600	600	4.00 mm	2,432	2009316

W = GENİŞLİK = WIDTH / T = KALINLIK = THICKNESS

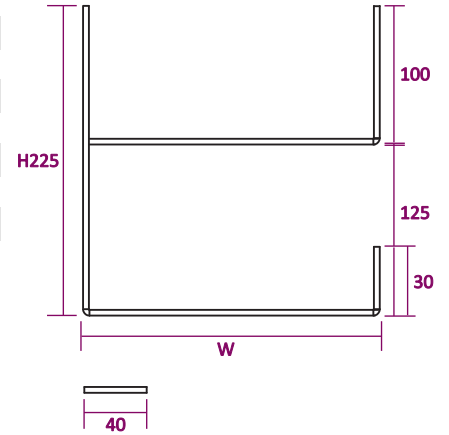

ARTIM METAL ELEKTRİK A.Ş.

* Farklı kalınlık ve ölçülerde üretim yapılabılır.
* Malzeme ağırlıkları yaklaşık değerlerdir, \pm %10 değişiklik gösterebilir.
* Malzeme kalınlık toleransı \pm %10 dur.
* Lütfen siparişlerinizde sipariş kodu veya ürün kodu ve Kaplama şeklini belirtiniz.

* We can produce cable trays different thickness and dimensions
* Cable trays are shown approximately weight, they could change \pm %10 difference.
* Cable trays thickness tolerances are shown \pm %10 .
* Please indicate order code and coating type in your orders.

AG SERIES

GEMİ TIPI ASKI SİSTEMLERİ

MARINE TYPE SUPPORT SYSTEM

SICAK DALDIRMA (SD)
HOT DIP GALVANIZED (SD)
TS EN ISO 1461

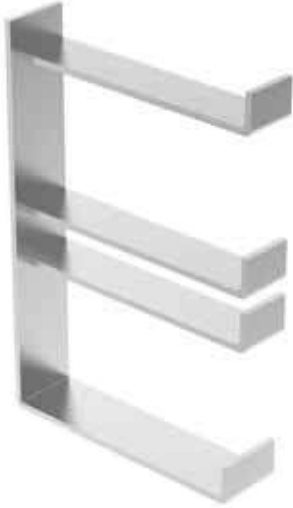

E KONSOL / E BRACKET

Sipariş Kodu Order Code	W (mm)	T (mm)	Ağırlık (kg/ad) Weight (kg/ad)	Barkod Kodu Barcode Code
AG EK 100	100	4.00 mm	1,337	2009351
AG EK 150	150	4.00 mm	1,648	2009352
AG EK 200	200	4.00 mm	1,958	2009353
AG EK 250	250	4.00 mm	2,269	2009354
AG EK 300	300	4.00 mm	2,580	2009355
AG EK 400	400	4.00 mm	3,202	2009356
AG EK 500	500	4.00 mm	3,824	2009357
AG EK 600	600	4.00 mm	4,445	2009358

W = GENİŞLİK = WIDTH / T = KALINLIK = THICKNESS

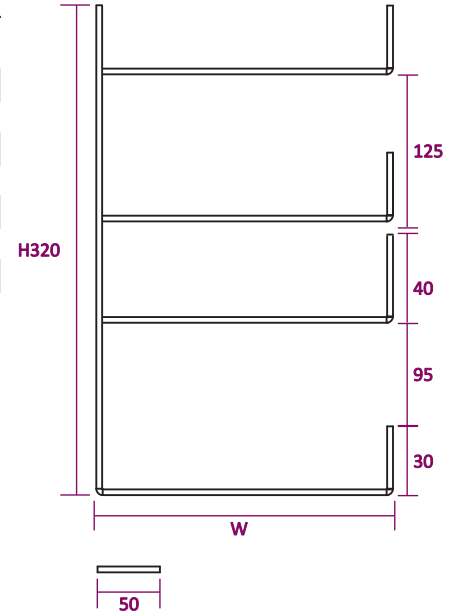

UZUN E KONSOL / E LONG BRACKET

Sipariş Kodu Order Code	W (mm)	T (mm)	Ağırlık (kg/ad) Weight (kg/ad)	Barkod Kodu Barcode Code
AG UEK 100	100	4.00 mm	1,556	2009359
AG UEK 150	150	4.00 mm	1,865	2009360
AG UEK 200	200	4.00 mm	2,176	2009361
AG UEK 250	250	4.00 mm	2,487	2009362
AG UEK 300	300	4.00 mm	2,798	2009363
AG UEK 400	400	4.00 mm	3,419	2009364
AG UEK 500	500	4.00 mm	4,041	2009365
AG UEK 600	600	4.00 mm	4,663	2009366

W = GENİŞLİK = WIDTH / T = KALINLIK = THICKNESS

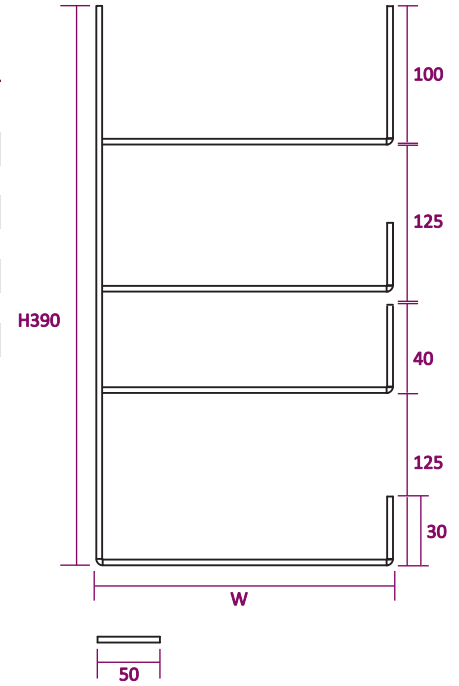

* Farklı kalınlık ve ölçülerde üretim yapılabılır.
* Malzeme ağırlıkları yaklaşık değerlerdir, ± %10 değişiklik gösterebilir.
* Malzeme kalınlık toleransı ± %10 dur.
* Lütfen siparişlerinizde sipariş kodu veya ürün kodu ve kaplama şeklini belirtiniz.

* We can produce cable trays different thickness and dimensions
* Cable trays are shown approximately weight, they could change ± %10 difference.
* Cable trays thickness tolerances are shown ± %10 .
* Please indicate order code and coating type in your orders.

AG SERIES

GEMİ TIPI ASKI SİSTEMLERİ

MARINE TYPE SUPPORT SYSTEM

SICAK DALDIRMA (SD)
HOT DIP GALVANIZED (SD)
TS EN ISO 1461



LAMBA AYAĞI / SUPPORT FOR LAMP

Sipariş Kodu Order Code	W (mm)	T (mm)	Ağırlık (kg/ad) Weight (kg/ad)	Barkod Kodu Barcode Code
AG LAA	60	4.00 mm	0,342	2009390

W = GENİŞLİK = WIDTH / T = KALINLIK = THICKNESS

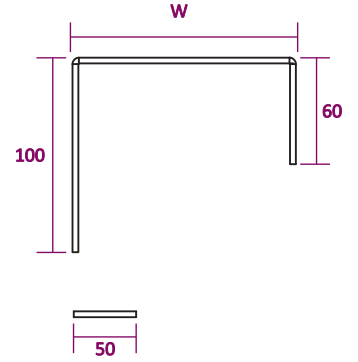

HARİCİ LAMBA AYAĞI / SUPPORT FOR EXTERNAL LAMP

Sipariş Kodu Order Code	W (mm)	T (mm)	Ağırlık (kg/ad) Weight (kg/ad)	Barkod Kodu Barcode Code
AG HLAA	100	4.00 mm	0,591	2009391

W = GENİŞLİK = WIDTH / T = KALINLIK = THICKNESS

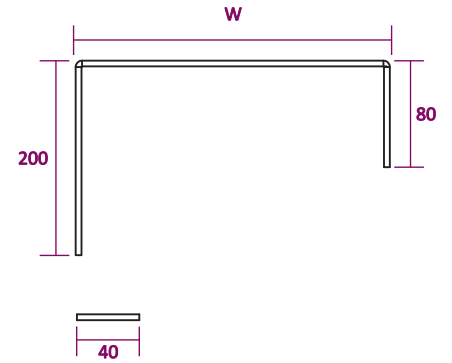

ARTIM METAL ELEKTRİK A.Ş.

* Farklı kalınlık ve ölçülerde üretim yapılabılır.
* Malzeme ağırlıkları yaklaşık değerlerdir, \pm %10 değişiklik gösterebilir.
* Malzeme kalınlık toleransı \pm %10 dur.
* Lütfen siparişlerinizde sipariş kodu veya ürün kodu ve Kaplama şeklini belirtiniz.

* We can produce cable trays different thickness and dimensions
* Cable trays are shown approximately weight, they could change \pm %10 difference.
* Cable trays thickness tolerances are shown \pm %10 .
* Please indicate order code and coating type in your orders.